





**Industrias  
GALARZA, S.A.**<sup>®</sup>

Leaders in electrical conductivity since 1958

**CATALOGUE 2020**

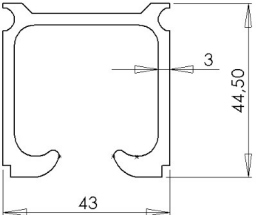

TRACK PROFILE	MAX. LOAD PER TROLLEY	DESCRIPTION	SERIES
	<b>30 KG</b>	<b>FESTOON SYSTEM RUNNING ON ALUMINIUM C-PROFILE 43 X 44,5MM</b>  Max cable package: 90 (L) x 30 (H) mm	<b>2310</b> 



# GENERAL SALES CONDITIONS, SUPPLY AND WARRANTY

## Generalities

The supply of the products contained in this catalogue is subject to the conformity of the tariff in force at the moment and the terms contained in these General Conditions of Sale and Guarantees.

## Orders and prices

All orders received by IGA will be confirmed via fax or email. If in the following 24 hours IGA does not receive any claim, they will be considered definitive. IGA reserves the right to accept or reject any order.

## Codes

The codes indicated in this catalogue are the standard products of IGA.

## Delivery time

If for reasons beyond our control we can not fulfill this service commitment, IGA will inform the customer of the new term within a maximum of 48 hours after the reception of the order.

The rest of references will be served in the shortest period of time possible and may make partial deliveries.

Orders received that have a delivery time less than 72 hours, will follow the procedure described above.

The breach of the previous commitment or a fractioned issue will not be grounds for compensation.

## Transport

Our products are considered expired in our warehouse and the date of issue is shown on the delivery note.

The goods travels at the addressee expense and risk, even if they are sent prepaid.

In the case of lack of packages or visible damages due to transportation, the addressee must write it down on the delivery note, claim the carrier and inform the commercial department of IGA within 48 hours. Otherwise, it will be considered the conformity of the goods in quantity and condition . Claims for delays in transportation will not be accepted.

After 8 days from receipt of the goods, no claims will be accepted about the contents of the boxes.

## Refunds

The products invoiced by IGA are considered a firm sale and has no right to refund.

In case of an error in the execution of the order, the following shall be taken into account:

-The change must be authorized by the commercial direction of IGA. The warehouse of IGA will not accept any product without authorization.

-The accepted material will have a 20% reduction of its value for verification expenses.

-The goods returned to IGA travel at the client's risk.

## Installations

IGA is exempted from any responsibility in the installations that do not comply with the advice or with the specifications and features of each range of product.

## Warranty

IGA range of products has a 2 year warranty. The acknowledgment of the responsibility in warranty corresponds only to IGA and / or to its insurance company. Any other defect caused by aging, corrosion, improper installation or improper application, will not be subject to possible claims.

## Jurisdiction

IGA will try to resolve any divergence with his clients through friendly channels. Having said that, in case of litigation, the parties agree and are obliged to submit to the arbitration appointed by the Court of the Arbitration Association of Bilbao, which will be responsible for the administration of the aforementioned arbitration in accordance with its Statute and Regulations. Likewise, they are obliged from now on to comply with the arbitral report that is issued.

IGA reserves the modification of the articles without previous notice.

## NOTES OF INTEREST

### KIT FESTOON

IGA offers the possibility of supplying the entire FESTOON system assembled under the customer's specifications.



Twitter  
@indgalarza



Facebook  
Industrias Galarza, S.A.



LinkedIn  
Industrias Galarza, S.A.

## INDEX

Profile	Page. 03	Assembly set	Page. 06
Joint	Page. 03	Accessories	Page. 06
Support	Page. 03	TROLLEYS FOR ROUND CABLE	
TROLLEYS PLATFORM- ROUND CABLE		End clamp	Page. 07
End clamp	Page. 04	Cable trolley	Page. 07
Cable trolley	Page. 04	Towing trolley	Page. 07
Towing trolley	Page. 05	Cable holder & "T" union	Page. 08
Pendant control unit trolley	Page. 05	Assembly instructions	Page. 09-10

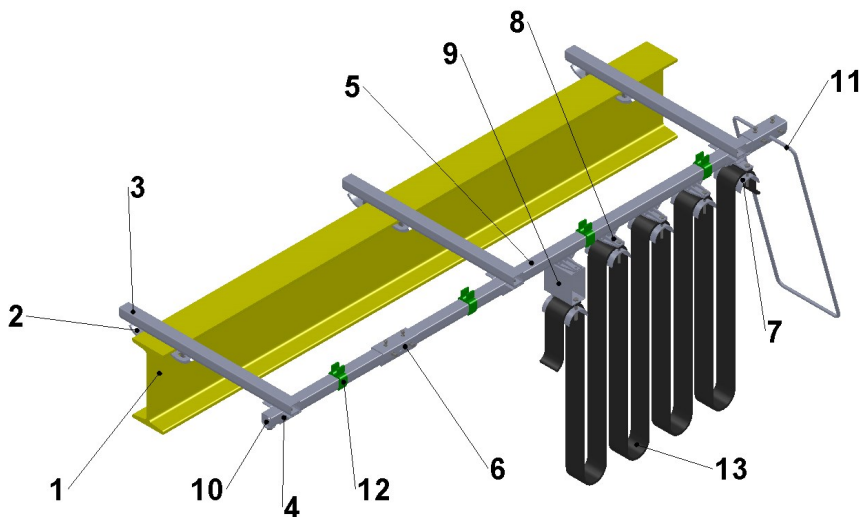

1. Beam
2. Beam clip
3. Cross arm support
4. Track hanger
5. Track profile
6. Track joint
7. End clamp
8. Cable trolley
9. Towing trolley
10. End bumper stop
11. Protection
12. Cable clamp
13. Flat pvc cable

Maximum cable package: 90 (L) X 30 (H) mm.

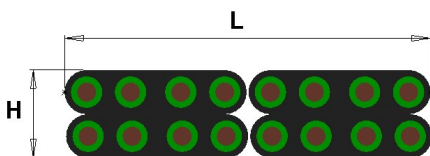

In aggressive indoor / outdoor conditions the metal components (bodies and cable holders) are supplied with EPOXY paint or made in stainless steel AISI 304, where allowed.

TEMPERATURE RANGE: -15°C / +80°C.

MAX. LOAD CAPACITY PER TROLLEY = 30 KG.

### NUMBER OF TROLLEYS REQUIRED:

$$N = ( L / 2xH ) - 1$$

Where: N: number of cable trolleys  
L: travelling length  
H: maximum loop height

### REQUIRED AMBUSH LENGTH

$$b = ( N + 1 ) x m$$

Where: b: maximum ambush length  
N: number of cable trolleys  
m: trolley length

## PROFILE

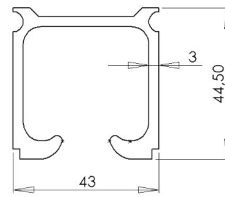

REFERENCE	CODE	MATERIAL	TRACK LENGTH	WEIGHT
2310-1	304001	Aluminium	5 mts	1,2 Kg/m

## JOINT

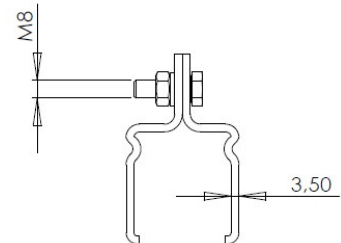
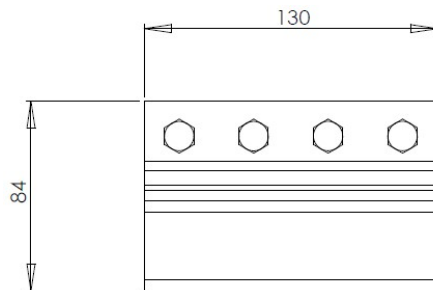

REFERENCE	CODE	MATERIAL		WEIGHT
		Laterals	Screws	
2310-3	304003	Zinc plated steel	Zinc plated steel	0,639 Kg
2310-3-PLY	304019	Painted steel	Stainless steel	0,639 Kg

## SUPPORT

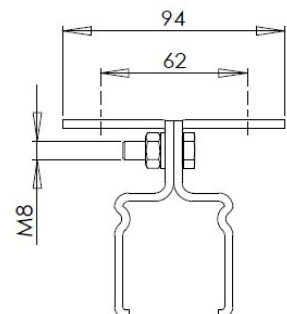
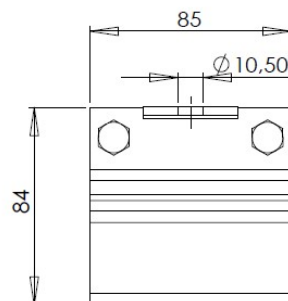

REFERENCE	CODE	MATERIAL		WEIGHT
		Laterals	Screws	
2310-4	304004	Zinc plated steel	Zinc plated steel	0,452 Kg
2310-4-PLY	304020	Painted steel	Stainless steel	0,462 Kg



# FESTOON SYSTEM Series 2310

## END CLAMP

Saddle  $\varnothing 90\text{mm}$

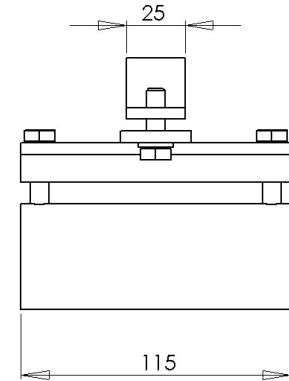
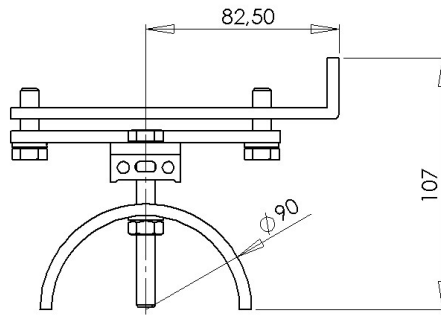
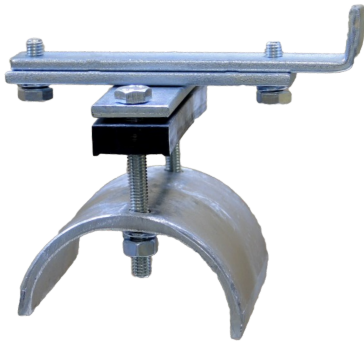

OPTION SADDLE  $\varnothing 120\text{mm}$  AVAILABLE IN STEEL

REFERENCE	CODE	MATERIAL			WEIGHT
		Body	Screws	Saddle	
2310-2	304002	Zinc plated steel	Zinc plated steel	Aluminium	0,860 Kg
2310-2-PLY	304018	Painted steel	Stainless steel	Painted aluminium	0,870 Kg

## CABLE TROLLEY

Saddle  $\varnothing 90\text{mm}$

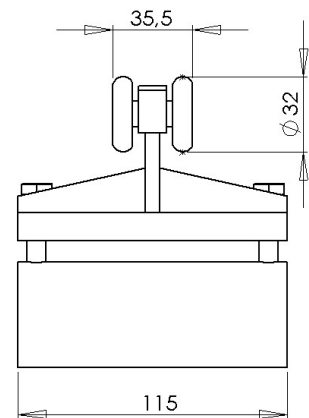
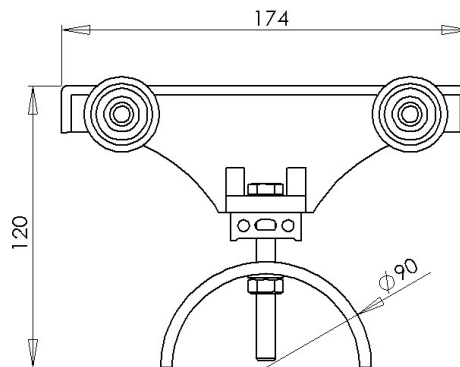

OPTION SADDLE  $\varnothing 120\text{mm}$  AVAILABLE IN STEEL

REFERENCE	CODE	MATERIAL			WEIGHT
		Body	Ball bearings + Screws	Saddle	
2310-5	304005	Aluminium	Zinc plated steel	Aluminium	0,660 Kg
2310-5 PLY	304021	Painted aluminium	Stainless steel	Painted aluminium	0,670 Kg



# FESTOON SYSTEM Series 2310

## TOWING TROLLEY

Saddle  $\varnothing 90\text{mm}$

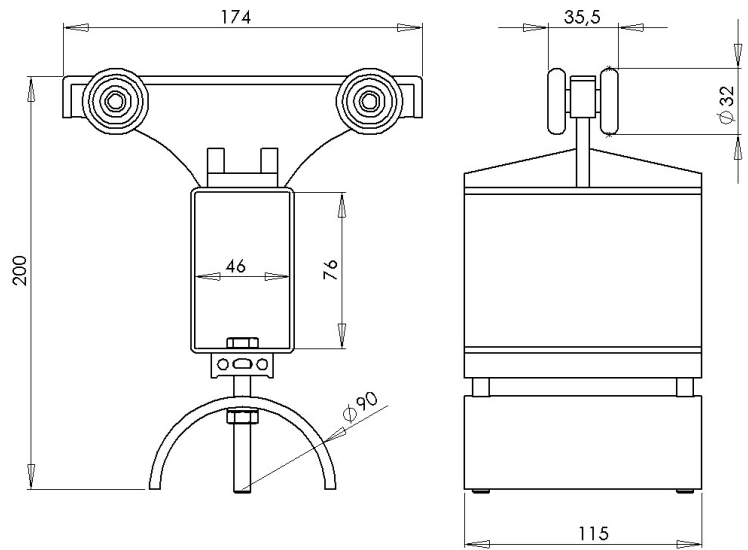

OPTION SADDLE  $\varnothing 120\text{mm}$  AVAILABLE IN STEEL

REFERENCE	CODE	MATERIAL				WEIGHT
		Body	Ball bearings + Screws	Towing attachment	Saddle	
2310-6	304006	Aluminium	Zinc plated steel	Zinc plated steel	Aluminium	1,242 Kg
2310-6-PLY	304022	Painted aluminium	Stainless steel	Painted steel	Painted aluminium	1,252 Kg

## PENDANT CONTROL UNIT TROLLEY

Saddle  $\varnothing 90\text{mm}$

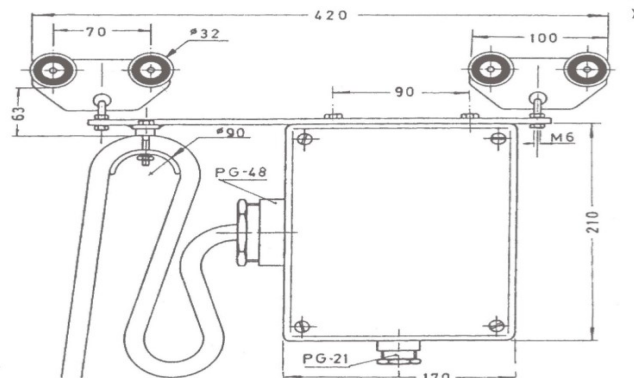
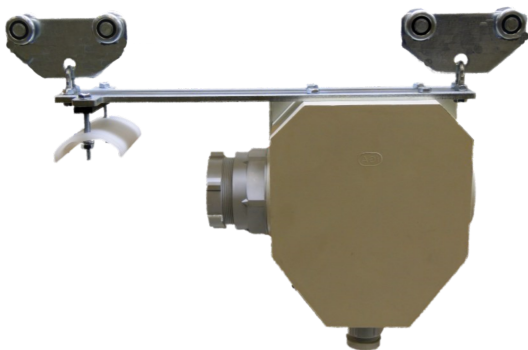

REFERENCE	CODE	MATERIAL					WEIGHT
		Body	Ball bearings + Screws	Saddle	Connection box	Cable Glands	
2310-7	304007	Zinc plated steel	Zinc plated steel	Aluminium	Polyester + glass fiber	Polyamide	2,372 Kg
2310-7-PLY	304023	Painted steel	Stainless steel	Painted aluminium	Polyester + glass fiber	Polyamide	2,372 Kg



# ACCESSORIES

## STANDARD BRACKETS Ref. CM-6

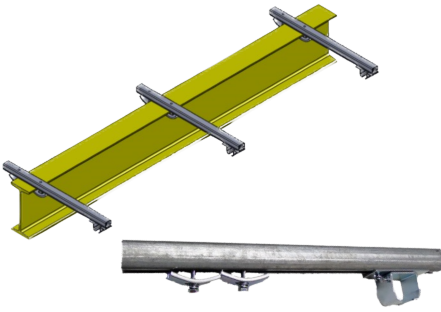

COMPOSED BY: REFERENCE	CODE	DESCRIPTION	MATERIAL	WEIGHT
2340-12-500	309006	Beam Clip	Zinc Plated Steel	0,156 Kg
2500-1(500mm)	805170	Support arm	Galvanised Steel	0,220 Kg
2500-4A-500	305155	Track support	Zinc Plated Steel	0,400 Kg
2340-12-500-Inox	309316	Beam Clip	Stainless Steel	0,156 Kg
2500-1-Inox (500mm)	805210	Support arm	Stainless Steel	0,220 Kg
2500-4A-500-Inox	305425	Track support	Stainless Steel	0,400 Kg

Cross support arm:  
- Profile 2500-1 (40x35mm): CM-6.

Point out the total length (L) of it. Example:  
- CM-6-500.

Brackets formed by:  
- 1 cross support arm 2500-1 (L).  
- 2 beam claws.  
- 1 track holder.

## BEAM CLAW

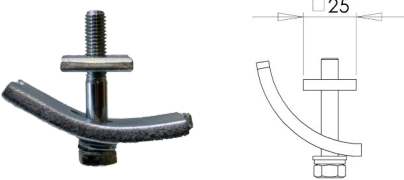

## TRACK HOLDER

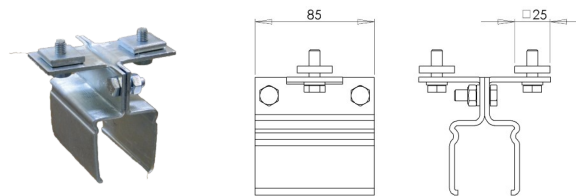

## SINGLE AXLE CARRYING TROLLEY

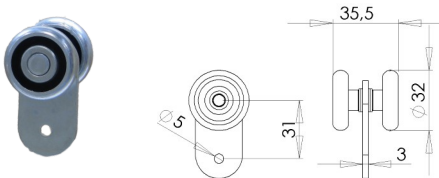

REFERENCE	CODE	MATERIAL		MAX. LOAD	WEIGHT
		Body	Ball bearings		
2330-32	304143	Zinc plated steel	Zinc plated steel	15 Kg	0,108 Kg
2330-32-Inox	304231	Stainless steel	Stainless steel	15 Kg	0,108 Kg

## DOUBLE AXLE CARRYING TROLLEY

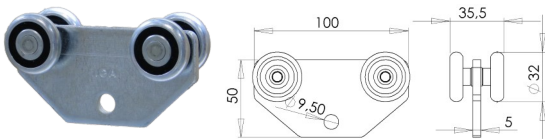

REFERENCE	CODE	MATERIAL		MAX. LOAD	WEIGHT
		Body	Ball bearings		
2330-D-32	304088	Zinc plated steel	Zinc plated steel	30 Kg	0,318 Kg
2330-D-32-Inox	304232	Stainless steel	Stainless steel	30 Kg	0,318 Kg

## CLAMP B

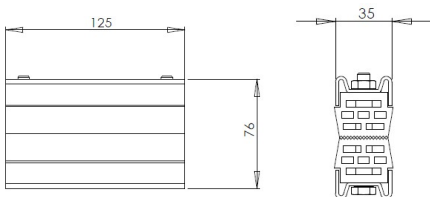

REFERENCE	CODE	MATERIAL				WEIGHT
		Metal section	Tightening profile	Nuts	Bolts	
B-90	304010	Zinc plated steel	Rubber	Brass	Zinc plated steel	0,593 Kg
B-90(TI)	317761	Zinc plated steel	Rubber	Brass	Stainless steel	0,593 Kg
B-90-Inox	317004	Stainless steel	Rubber	Brass	Stainless steel	0,593 Kg



## END CLAMP

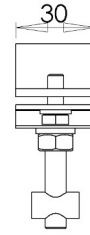
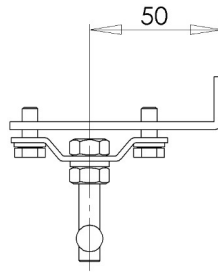

REFERENCE	CODE	MATERIAL	MAX. LOAD	WEIGHT
2336-2	304212	Zinc plated steel	30 Kg	0,285 Kg
2336-2-Inox	304233	Stainless steel	30 Kg	0,285 Kg

## CABLE TROLLEY

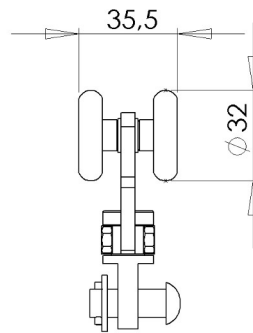
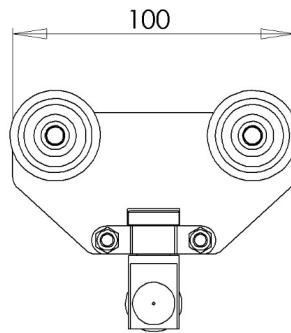

REFERENCE	CODE	MATERIAL	MAX. LOAD	WEIGHT
2336-5	304129	Zinc plated steel	30 Kg	0,408 Kg
2336-5-Inox	304234	Stainless steel	30 Kg	0,408 Kg

## TOWING TROLLEY

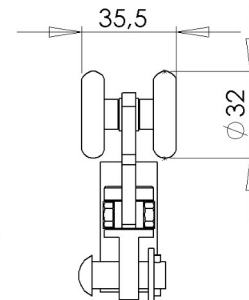
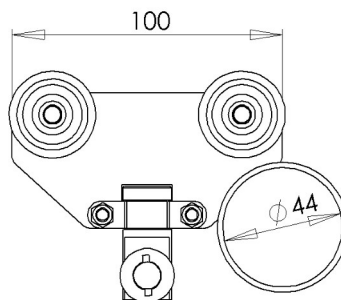
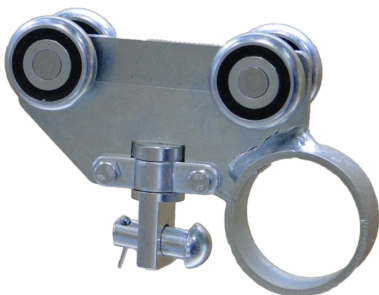

REFERENCE	CODE	MATERIAL	MAX. LOAD	WEIGHT
2336-6	304202	Zinc plated steel	30 Kg	0,469 Kg
2336-6-Inox	304235	Stainless steel	30 Kg	0,469 Kg





# SERIE 2310 SUPPORT SADDLE FOR ROUND CABLES AND HOSES



## CLIP "+A" for cables from $\varnothing 8\text{mm}$ to $\varnothing 15\text{mm}$

REFERENCE	CODE	MATERIAL	SCREWS	WEIGHT
+A	303251	Aluminium	Zinc plated steel	0,104 Kg
+A-Inox	303596	Aluminium	Stainless steel	0,104 Kg

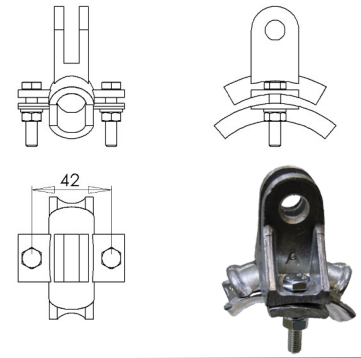

## CLIP "+B" for cables from $\varnothing 16\text{mm}$ to $\varnothing 24\text{mm}$

REFERENCE	CODE	MATERIAL	SCREWS	WEIGHT
+B	303252	Aluminium	Zinc plated steel	0,114 Kg
+B-Inox	303597	Aluminium	Stainless steel	0,114 Kg

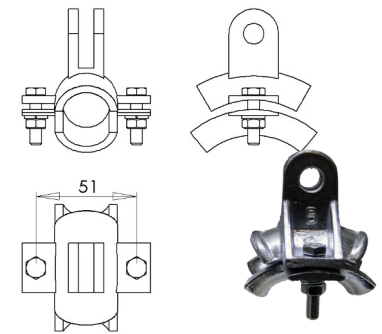

## CLIP "+C" for cables from $\varnothing 25\text{mm}$ to $\varnothing 35\text{mm}$

REFERENCE	CODE	MATERIAL	SCREWS	WEIGHT
+C	303253	Aluminium	Zinc plated steel	0,150 Kg
+C-Inox	303598	Aluminium	Stainless steel	0,150 Kg

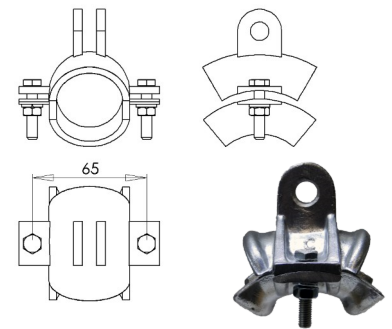

## "T" UNION

REFERENCE	CODE	MATERIAL	SCREWS + RIVET	WEIGHT
T	303496	Stainless steel	Zinc plated steel	0,107 Kg
T-Inox	303599	Stainless steel	Stainless steel	0,107 Kg

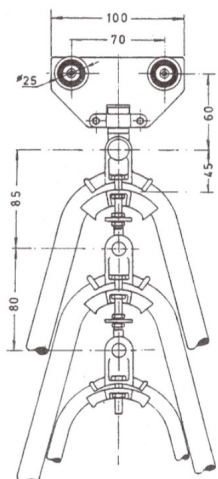
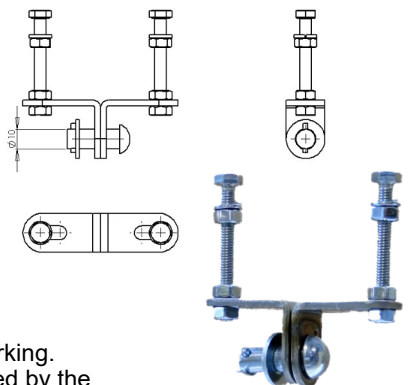

Intermedio - Ref. 2.335 + C + B + A-5

The clips makes a 90 degree turn in order to make easier the parking. When ordering, add to the reference, the necessary clips, followed by the indicative number: end clamp (-2), cable trolley (-5) or towing trolley (-6).

- Example:
- End clamp 2336+C+B-2.
  - Cable trolley 2336+B+B+A-5.
  - Towing trolley 2336+A-6.



# FESTOON SYSTEM Series 2310

## ASSEMBLY INSTRUCTIONS

### 1) SECURITY

#### 1.1 Advices about electricity

- Disconnect the power from the system before starting any assembly operation.
- Do not use electrical cables for higher loads than the specified voltage and current.

#### 1.2 Operational advices

- Do not use different cables for which the festoon system is specified. Any change in number, diameter, weight, etc., may affect the normal operation of the cable system.

#### 1.3 Consejos de mantenimiento

- The modification of the number and/or characteristics of the festoon system components cancels the warranty.

### 2) INSTALLATION

The support structure for the festoon system must be capable of supporting the total weight of the festoon system.

Place the support along the beam through which the hoist is to be circulated. These points must be located every 2m, except in the parking area where they must be located every 1m.



STANDARD BRACKETS



BEAM WELDED JOINT BAR



BEAM WELDED SUPPORT



Install the first profile in the supports 2310-4 without tightening the screws.



Assemble the next profile section on its corresponding supports 2310-4 in the same way as the first.



Join these profiles using the joints 2310-3 that guarantee a continuous travel between both sections. Tighten the screws once the joint has been placed in the middle of both profile sections. Repeat the same operation for the rest of the profile sections.



Once all the profiles have been assembled, we will proceed to align the path with respect to the rolling hoist on the beam, crane, etc. Once the alignment is correct, we will proceed to tighten the screws of the supports 2310-4.



# FESTOON SYSTEM Series 2310

## ASSEMBLY INSTRUCTIONS



Cut the necessary length of electrical cable leaving enough length on both sides to make the electrical connections later. Make marks with white chalk on the cable in the required points, according to the height of the loop or number of trolleys to be assembled. Put the cables in the saddle (biggest cables should be mounted on top of the cable package).

Tighten the screws of the cable holders avoiding damaging the cables due to excessive tightening. The cable package should be as centered as possible on the cable holder, so that the trolley runs in a balanced way. Make sure that the smallest cables do not slip into the cable package.



Insert the festoon system into the profile, starting first with the towing trolley and then following the cable trolleys. Insert the end clamp the last. The cables must be mounted without any rotation.

Tighten the end clamp at the end of the profile. Make the connections of the cables on both sides of the system in their respective connection boxes.

### 3 ) OPERATION

#### 3.1 Previous tests

Carry out several travels by hand to check that it moves throughout its length without problems.

Check that there is plenty of space in the ambush area.

Check that the cable loops don't get hooked in any part of the travel.

In the cable management system, check the correct height between the pushbutton pendant control station and the floor.

#### 3.2 Final tests

Once the electric current is connected, check that the trolleys move forward and backward without problems.

Check that the device, the festoon system is powered on, works correctly.

#### 3.3 Normal functioning

Do not exceed the maximum voltage and / or amperage specified for the electric cables.

Use the festoon system within its corresponding electrical and / or mechanical specifications.

### 4 ) MAINTENANCE

Perform periodic maintenance tasks to ensure the status of the festoon system. The maintenance operations will depend on the use given to the system.

During each inspection the following points should be checked:

- Wear of ball bearings.
- Ensure screws are correctly tightened.
- Separation or alignment in the joints.
- Electric cables: cuts, cracks, etc...
- The profile must be clean in the running edges.



# Industrias GALARZA, S.A.®

Leaders in electrical conductivity since 1958

## RANGE OF PRODUCTS



Multipole enclosed conductor systems

Single pole enclosed conductor systems

Materials for unguarded conductor systems

Insulators and moulded pieces



Festoon systems

Atex

Cable glands and electric cables

Cable reels

## MARKETS

CRANES



PORTS&CONTAINERS HANDLING



BULK MATERIAL HANDLING



METALLURGY



MINNING & ENERGY

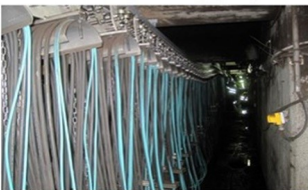

TUNNELLING



ENVIRONMENTAL TECHNOLOGY



WIND POWER



AUTOMOTIVE

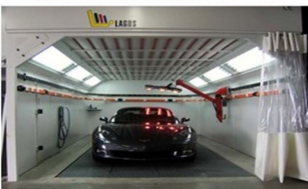

OFFSHORE



THEATRE STAGE TECH.



AGRICULTURE



INDUSTRIAS GALARZA S.A.  
 P.I. Bildosola, Pab. D-4  
 48142 ARTEA (BIZKAIA)  
 SPAIN  
 Tel. +34 944 47 18 12  
 Fax. +34 944 76 42 76  
 E.mail: [info@industriasmgalarza.com](mailto:info@industriasmgalarza.com)  
[www.industriasmgalarza.com](http://www.industriasmgalarza.com)

DISTRIBUTED BY: